

# Concept Test PowerPoints

## Chapter 21

### *Physics: Principles with Applications, 6<sup>th</sup> edition*

Giancoli

© 2005 Pearson Prentice Hall

This work is protected by United States copyright laws and is provided solely for the use of instructors in teaching their courses and assessing student learning. Dissemination or sale of any part of this work (including on the World Wide Web) will destroy the integrity of the work and is not permitted. The work and materials from it should never be made available to students except by instructors using the accompanying text in their classes. All recipients of this work are expected to abide by these restrictions and to honor the intended pedagogical purposes and the needs of other instructors who rely on these materials.

# ConceptTest 21.1a Magnetic Flux I

In order to change the magnetic flux through the loop, what would you have to do?

- 1) drop the magnet
- 2) move the magnet upwards
- 3) move the magnet sideways
- 4) only (1) and (2)
- 5) all of the above

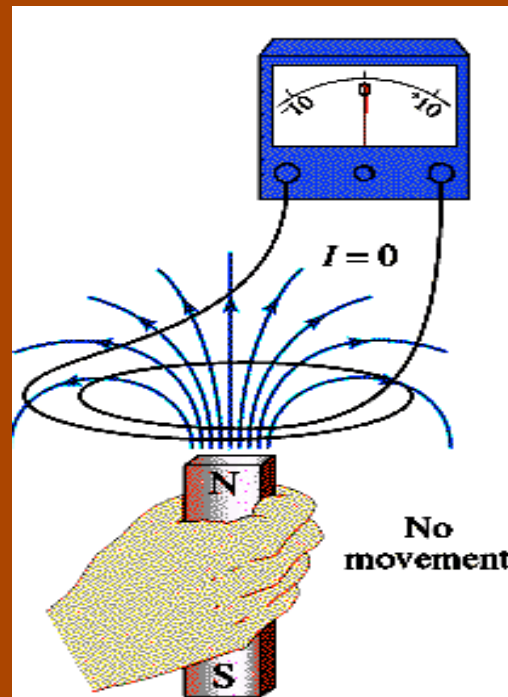

# ConceptTest 21.1a Magnetic Flux I

In order to change the magnetic flux through the loop, what would you have to do?

- 1) drop the magnet
- 2) move the magnet upwards
- 3) move the magnet sideways
- 4) only (1) and (2)
- 5) all of the above

Moving the magnet in **any direction** would change the magnetic field through the loop and thus the magnetic flux.

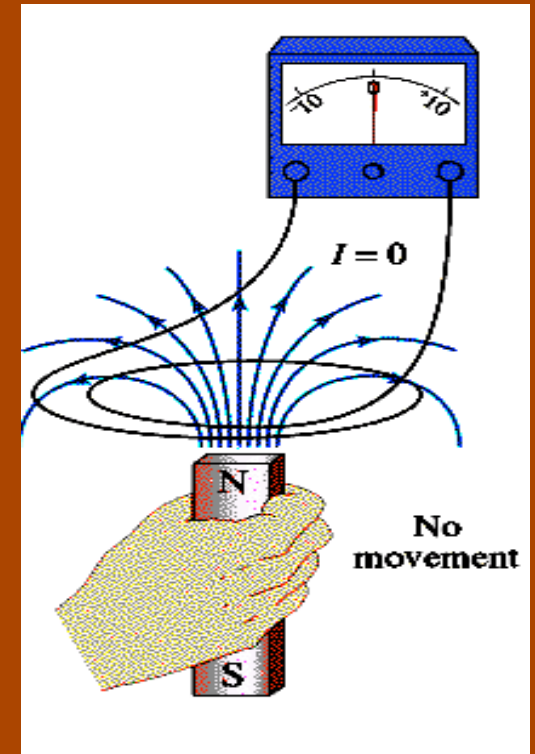

## ConceptTest 21.1b Magnetic Flux II

In order to change the magnetic flux through the loop, what would you have to do?

- 1) tilt the loop
- 2) change the loop area
- 3) use thicker wires
- 4) only (1) and (2)
- 5) all of the above

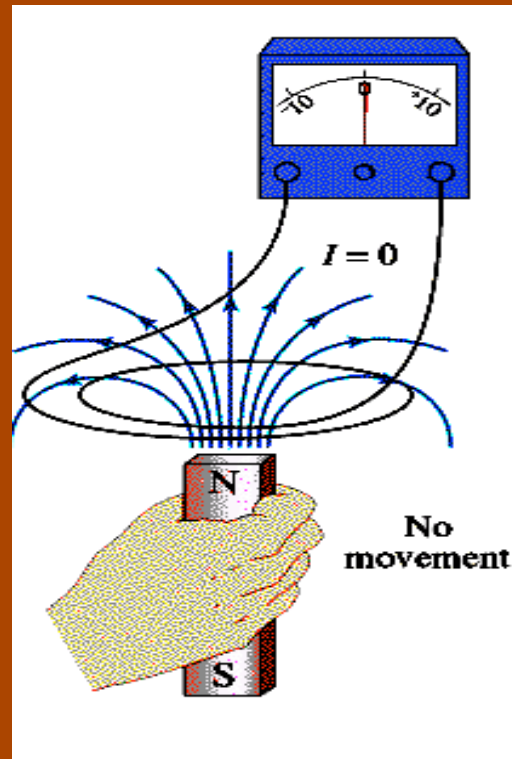

## ConceptTest 21.1b Magnetic Flux II

In order to change the magnetic flux through the loop, what would you have to do?

- 1) tilt the loop
- 2) change the loop area
- 3) use thicker wires
- 4) only (1) and (2)
- 5) all of the above

Since  $\Phi = B A \cos\theta$ , changing the area or tilting the loop (which varies the projected area) would change the magnetic flux through the loop.

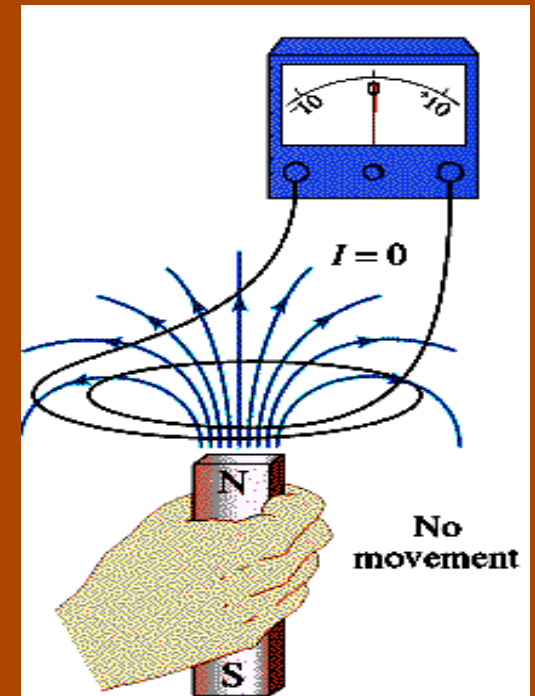

## ConceptTest 21.2a Moving Bar Magnet I

If a North pole moves toward the loop from above the page, in what direction is the induced current?

- 1) clockwise
- 2) counterclockwise
- 3) no induced current

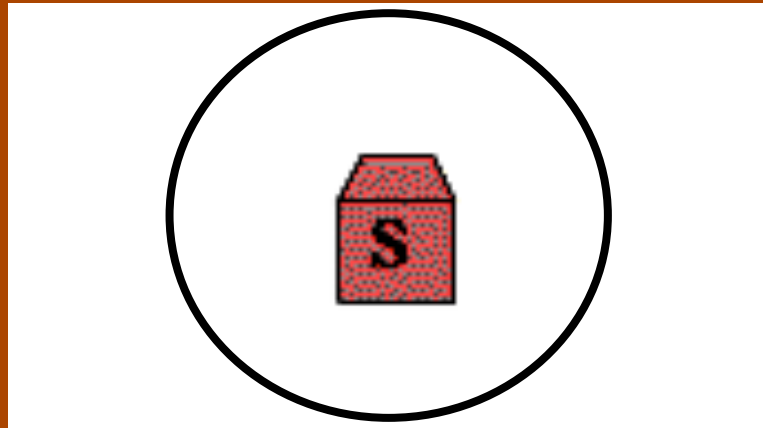

## ConceptTest 21.2a Moving Bar Magnet I

If a North pole moves toward the loop from above the page, in what direction is the induced current?

- 1) clockwise
- 2) counterclockwise
- 3) no induced current

The magnetic field of the moving bar magnet is pointing *into the page* and getting *larger* as the magnet moves closer to the loop. Thus the induced magnetic field has to point *out of the page*. A *counterclockwise* induced current will give just such an induced magnetic field.

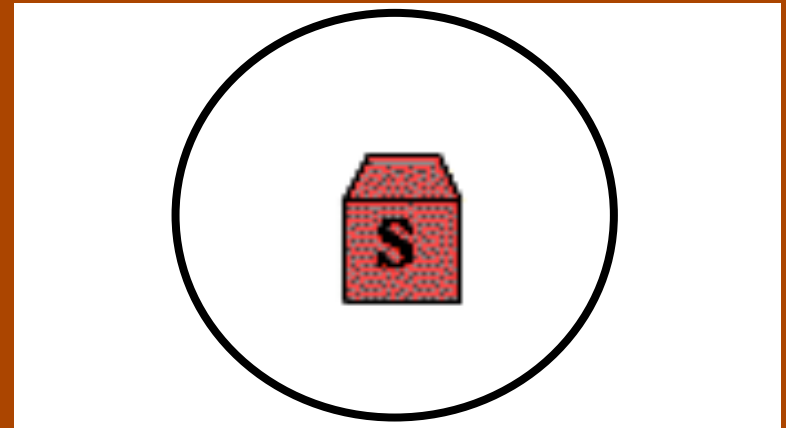

**Follow-up:** What happens if the magnet is stationary but the loop moves?

## ConceptTest 21.2b Moving Bar Magnet II

If a North pole moves toward the loop in the plane of the page, in what direction is the induced current?

- 1) clockwise
- 2) counterclockwise
- 3) no induced current

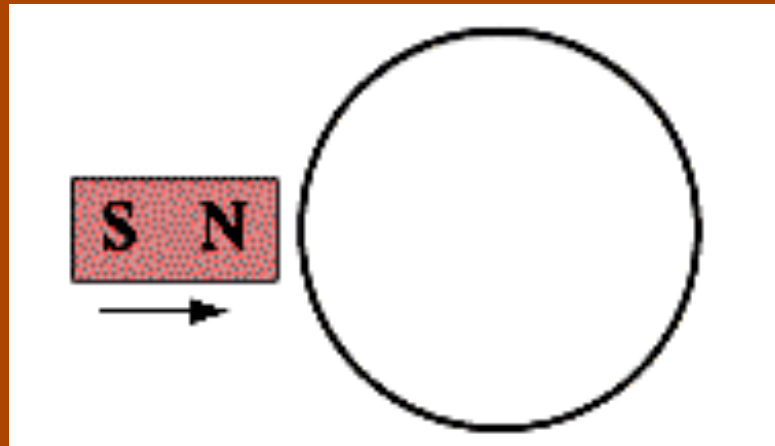



## ConceptTest 21.2b Moving Bar Magnet II

If a North pole moves toward the loop in the plane of the page, in what direction is the induced current?

- 1) clockwise
- 2) counterclockwise
- 3) no induced current

Since the magnet is moving parallel to the loop, there is **no magnetic flux through the loop**. Thus the **induced current is zero**.

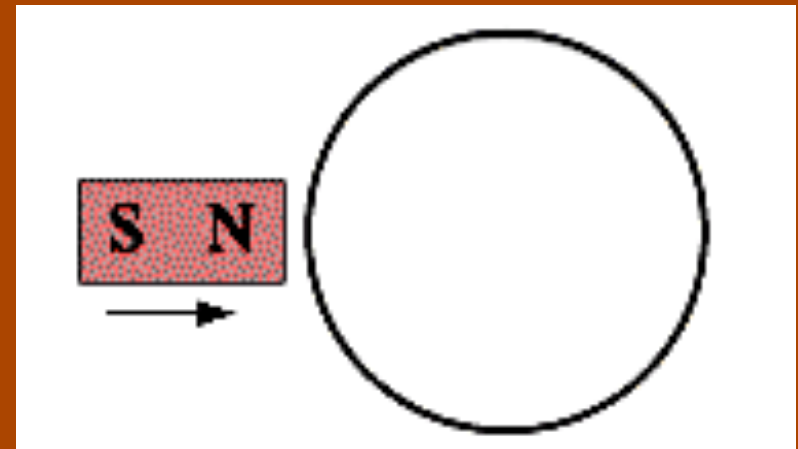

## ConceptTest 21.3a Moving Wire Loop I

A wire loop is being pulled through a uniform magnetic field. What is the direction of the induced current?

- 1) clockwise
- 2) counterclockwise
- 3) no induced current

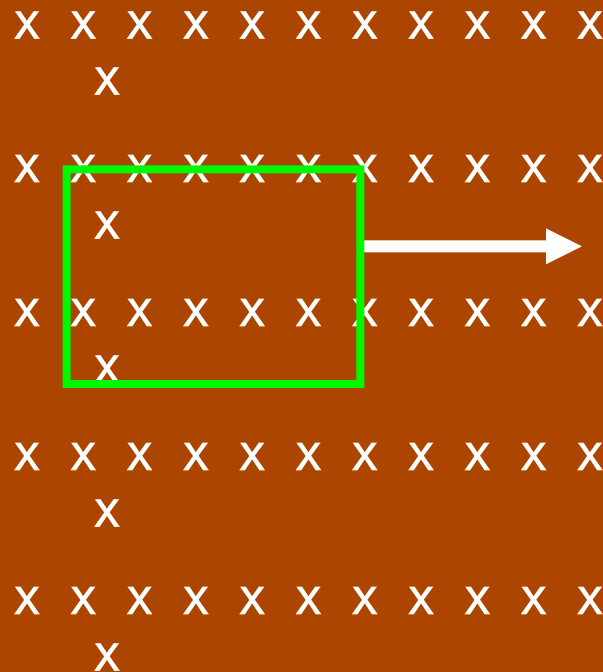

## ConceptTest 21.3a Moving Wire Loop I

A wire loop is being pulled through a uniform magnetic field. What is the direction of the induced current?

- 1) clockwise
- 2) counterclockwise
- 3) no induced current

Since the magnetic field is uniform, the magnetic flux through the loop is not changing. Thus **no current is induced**.

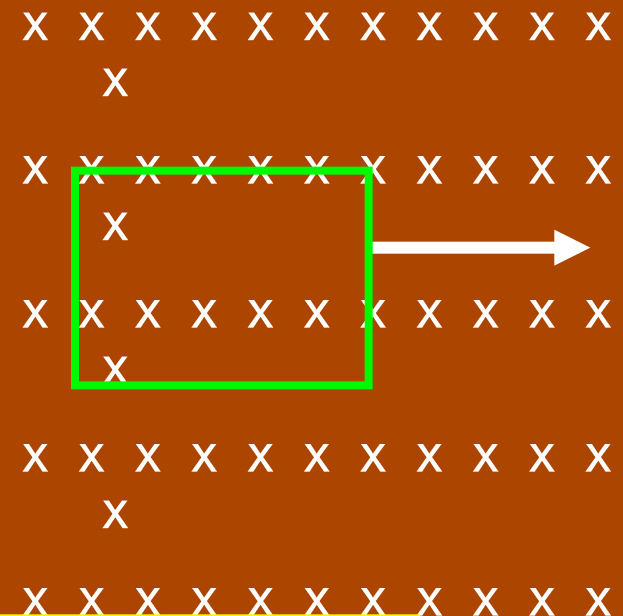

Follow-up: What happens if the loop moves out of the page?

## ConceptTest 21.3b Moving Wire Loop II

A wire loop is being pulled through a **uniform magnetic field that suddenly ends.**

What is the direction of the induced current?

- 1) clockwise
- 2) counterclockwise
- 3) no induced current

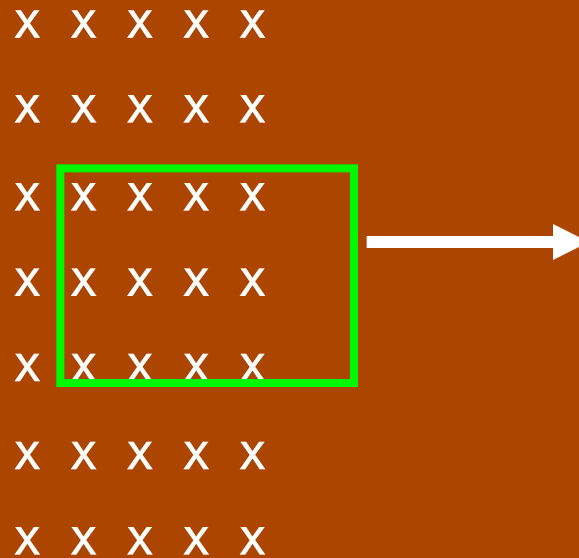

## ConceptTest 21.3b Moving Wire Loop II

A wire loop is being pulled through a **uniform magnetic field that suddenly ends**.

What is the direction of the induced current?

- 1) clockwise
- 2) counterclockwise
- 3) no induced current

The  **$B$  field into the page** is disappearing in the loop, so it must be compensated by an **induced flux also into the page**. This can be accomplished by an **induced current in the clockwise direction** in the wire loop.

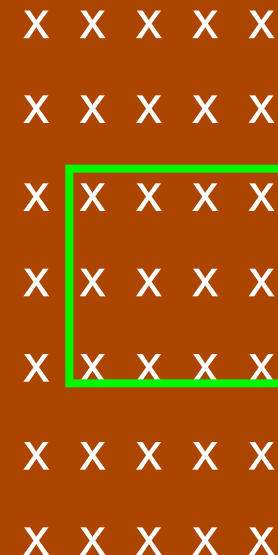

**Follow-up:** What happens when the loop is completely out of the field?

# ConceptTest 21.3c Moving Wire Loop III

What is the direction of the induced current if the **B field suddenly increases** while the loop is in the region?

- 1) clockwise
- 2) counterclockwise
- 3) no induced current

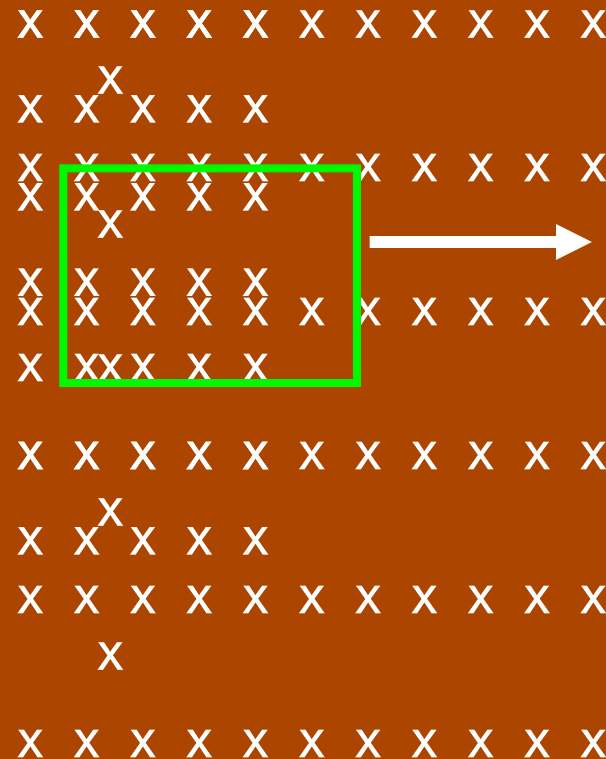

## ConceptTest 21.3c Moving Wire Loop III

What is the direction of the induced current if the  $B$  field suddenly increases while the loop is in the region?

- 1) clockwise
- 2) counterclockwise
- 3) no induced current

The increasing  $B$  field into the page must be countered by an induced flux out of the page. This can be accomplished by induced current in the counterclockwise direction in the wire loop.

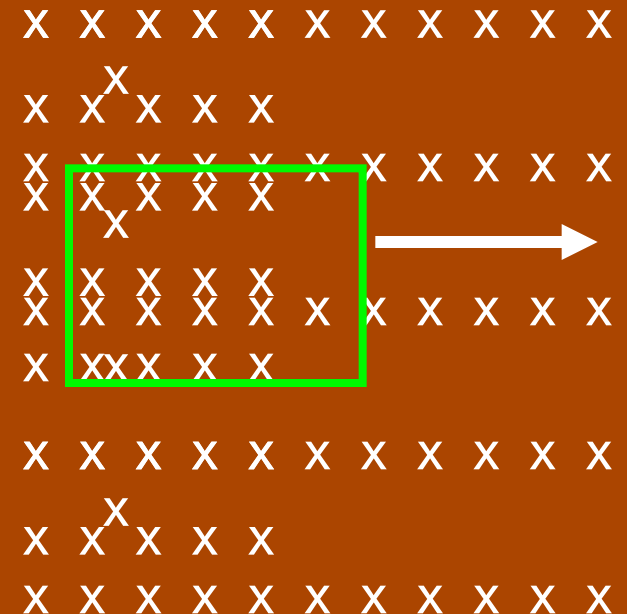

Follow-up: What if the loop stops moving while the field increases?



## ConceptTest 21.4 Shrinking Wire Loop

If a coil is shrinking in a magnetic field pointing into the page, in what direction is the induced current?

- 1) clockwise
- 2) counterclockwise
- 3) no induced current

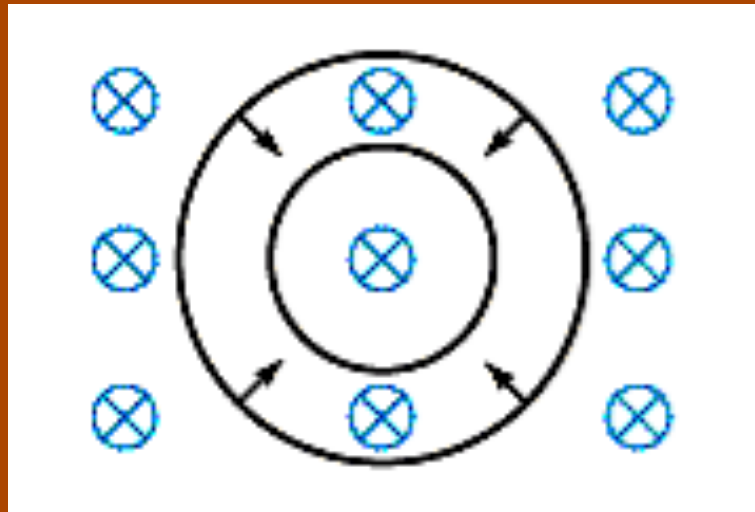



## ConceptTest 21.4 Shrinking Wire Loop

If a coil is shrinking in a magnetic field pointing into the page, in what direction is the induced current?

- 1) clockwise
- 2) counterclockwise
- 3) no induced current

The magnetic flux through the loop is *decreasing*, so the induced B field must try to reinforce it and therefore points in the same direction — *into the page*. According to the right-hand rule, an induced *clockwise* current will generate a magnetic field *into the page*.

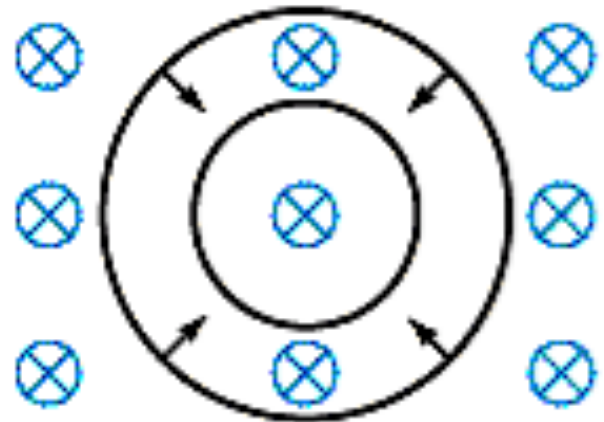

Follow-up: What if the  $B$  field is oriented at  $90^\circ$  to its present direction?

## ConceptTest 21.5 Rotating Wire Loop

If a coil is rotated as shown, in a magnetic field pointing to the left, in what direction is the induced current?

- 1) clockwise
- 2) counterclockwise
- 3) no induced current

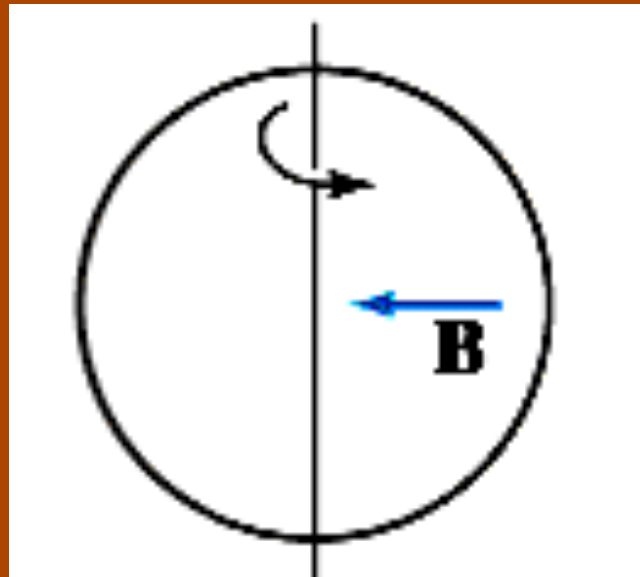

## ConceptTest 21.5 Rotating Wire Loop

If a coil is rotated as shown, in a magnetic field pointing to the left, in what direction is the induced current?

- 1) clockwise
- 2) counterclockwise
- 3) no induced current

As the coil is rotated into the  $B$  field, the magnetic flux through it *increases*. According to Lenz's Law, the induced  $B$  field has to *oppose this increase*, thus the new  $B$  field points *to the right*. An induced *counterclockwise* current produces just such a  $B$  field.

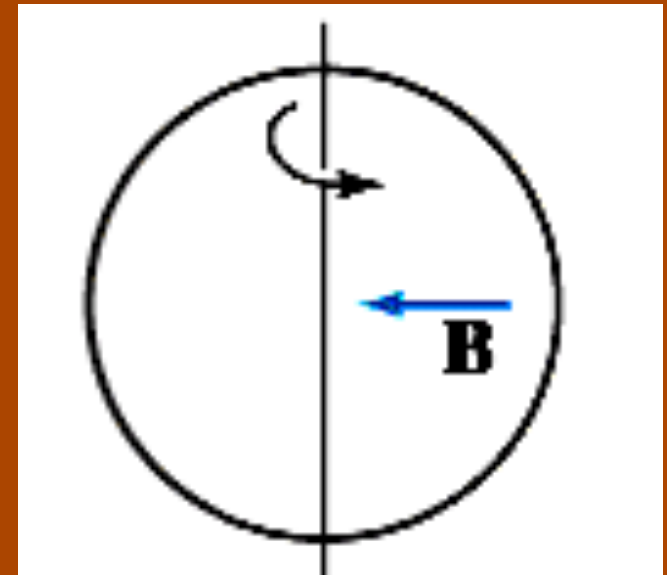

# ConceptTest 21.6a Voltage and Current I

**Wire #1** (length  $L$ ) forms a **one-turn loop**, and a bar magnet is dropped through.

**Wire #2** (length  $2L$ ) forms a **two-turn loop**, and the same magnet is dropped through.

Compare the magnitude of the **induced voltages** in these two cases.

1)  $V_1 > V_2$

2)  $V_1 < V_2$

3)  $V_1 = V_2 \neq 0$

4)  $V_1 = V_2 = 0$

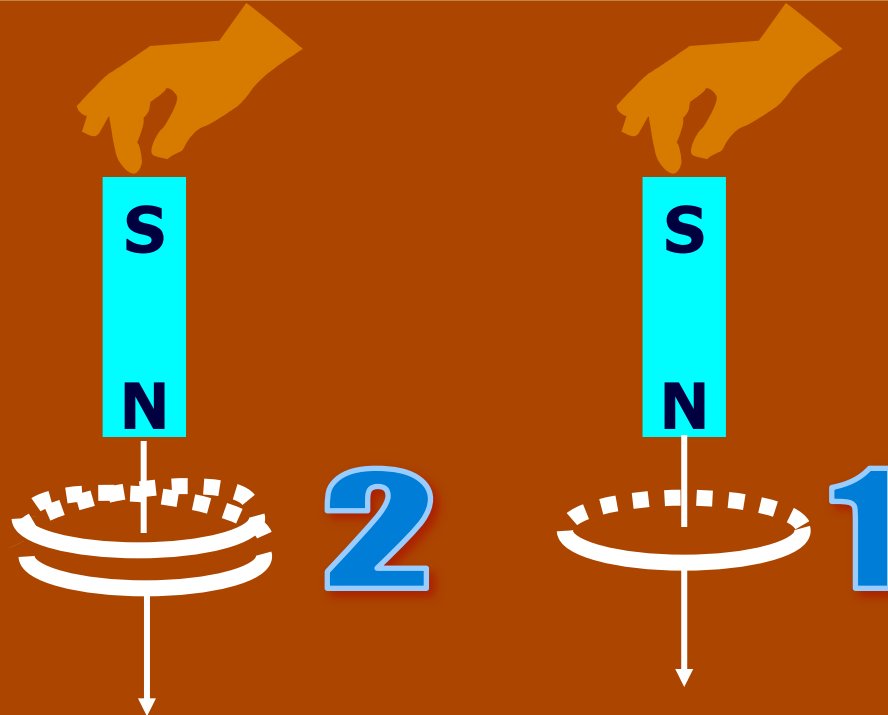

# ConceptTest 21.6a Voltage and Current I

**Wire #1** (length  $L$ ) forms a **one-turn loop**, and a bar magnet is dropped through.

**Wire #2** (length  $2L$ ) forms a **two-turn loop**, and the same magnet is dropped through.

Compare the magnitude of the **induced voltages** in these two cases.

1)  $V_1 > V_2$

2)  $V_1 < V_2$

3)  $V_1 = V_2 \neq 0$

4)  $V_1 = V_2 = 0$

Faraday's law:

$$\mathcal{E} = -N \frac{\Delta\Phi_B}{\Delta t}$$

depends on  $N$  (number of loops) so the **induced emf is twice as large in the wire with 2 loops.**

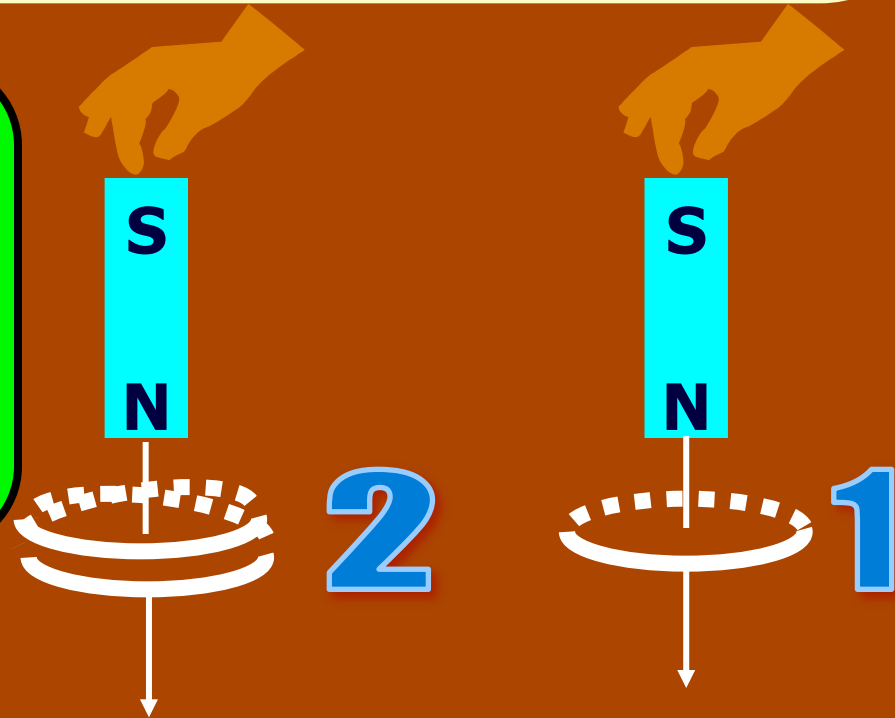

## ConceptTest 21.6b Voltage and Current II

**Wire #1** (length  $L$ ) forms a **one-turn loop**, and a bar magnet is dropped through.

**Wire #2** (length  $2L$ ) forms a **two-turn loop**, and the same magnet is dropped through.

Compare the magnitude of the **induced currents** in these two cases.

1)  $I_1 > I_2$

2)  $I_1 < I_2$

3)  $I_1 = I_2 \neq 0$

4)  $I_1 = I_2 = 0$

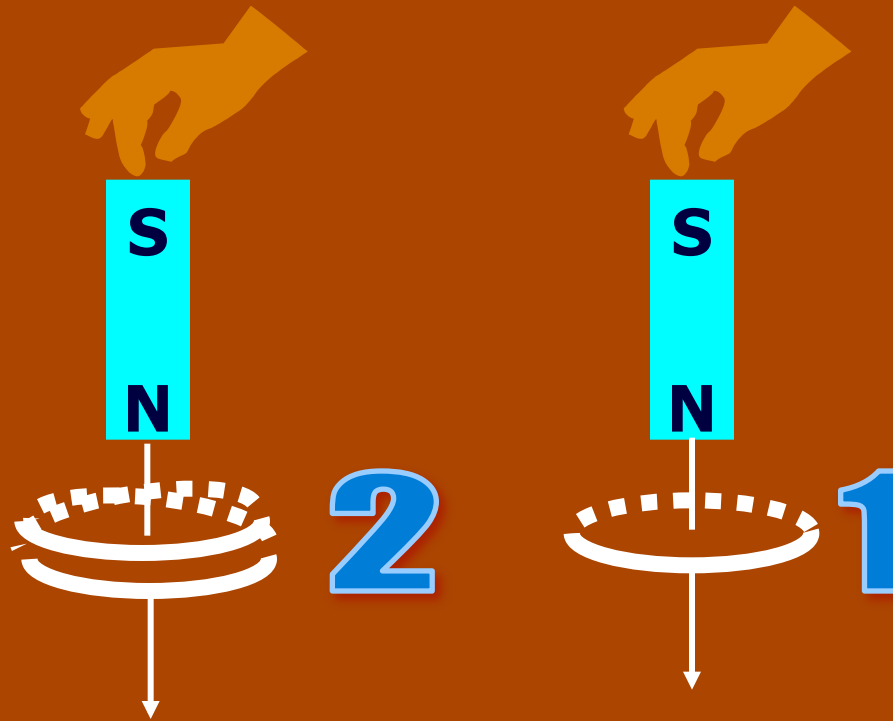

# ConceptTest 21.6b Voltage and Current II

**Wire #1** (length  $L$ ) forms a **one-turn loop**, and a bar magnet is dropped through.

**Wire #2** (length  $2L$ ) forms a **two-turn loop**, and the same magnet is dropped through.

Compare the magnitude of the **induced currents** in these two cases.

1)  $I_1 > I_2$

2)  $I_1 < I_2$

3)  $I_1 = I_2 \neq 0$

4)  $I_1 = I_2 = 0$

Faraday's law:

$$\mathcal{E} = -N \frac{\Delta\Phi_B}{\Delta t}$$

says that the induced emf is **twice as large** in the wire with **2 loops**. The current is given by Ohm's law:  $I = V/R$ . Since **wire #2 is twice as long as wire #1**, it has **twice the resistance**, so the current in both wires is the same.

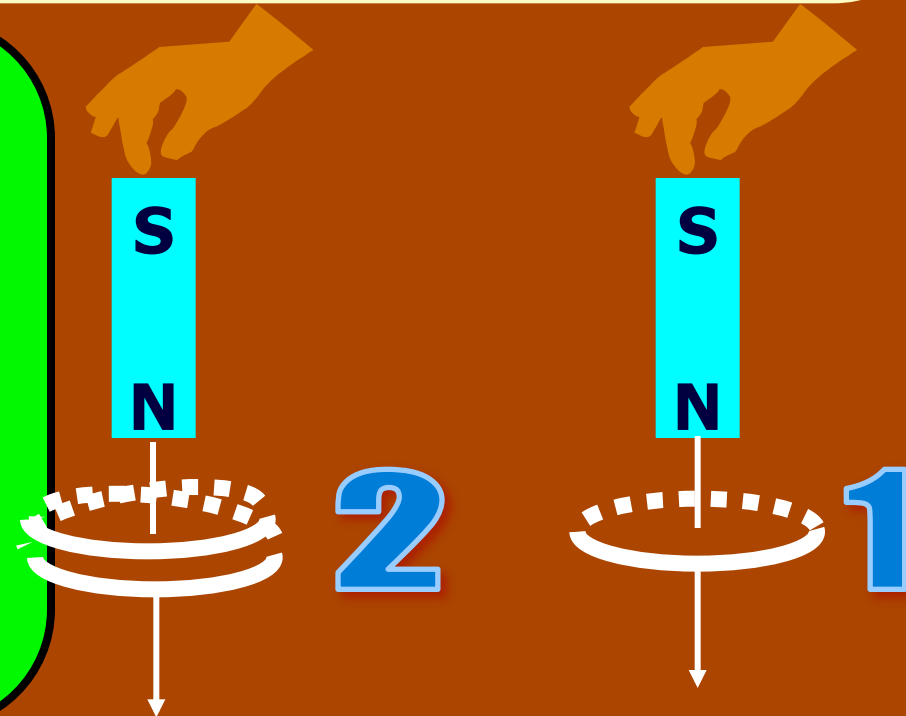

## ConceptTest 21.7a Falling Magnet I

A bar magnet is held above the floor and dropped. In 1, there is nothing between the magnet and the floor. In 2, the magnet falls through a copper loop. How will the magnet in case 2 fall in comparison to case 1?

- 1) it will fall slower
- 2) it will fall faster
- 3) it will fall the same

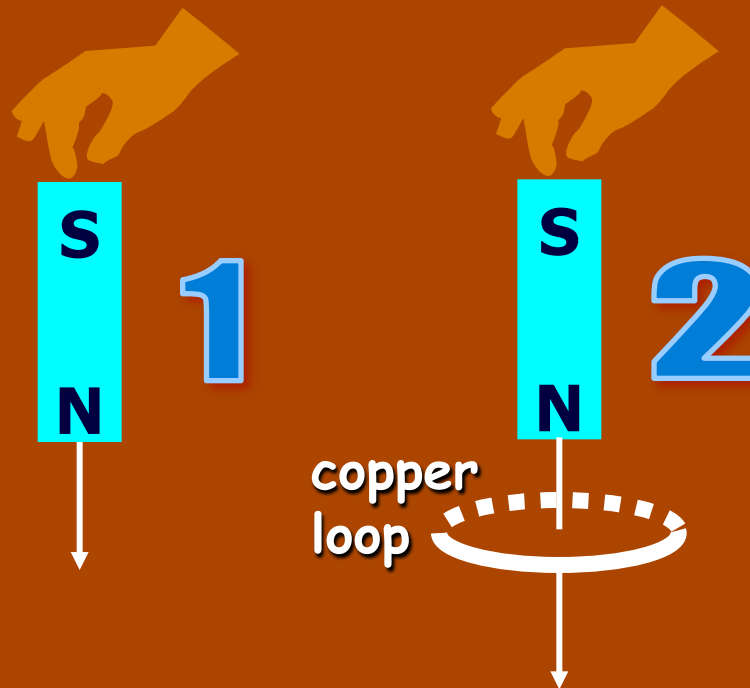



## ConceptTest 21.7a Falling Magnet I

A bar magnet is held above the floor and dropped. In 1, there is nothing between the magnet and the floor. In 2, the magnet falls through a copper loop. How will the magnet in case 2 fall in comparison to case 1?

- 1) it will fall slower
- 2) it will fall faster
- 3) it will fall the same

When the magnet is falling from *above* the loop in 2, the induced current will produce a *North pole on top of the loop*, which repels the magnet.

When the magnet is *below* the loop, the induced current will produce a *North pole on the bottom of the loop*, which attracts the South pole of the magnet.

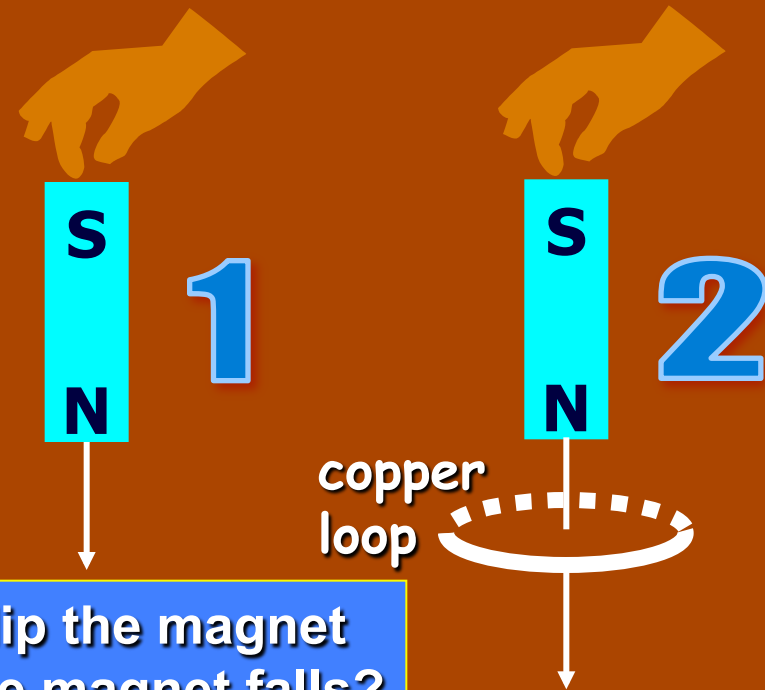

**Follow-up:** What happens in case 2 if you flip the magnet so that the South pole is on the bottom as the magnet falls?

## ConceptTest 21.7b Falling Magnet II

If there is induced current, doesn't that cost energy? Where would that energy come from in case 2?

- 1) induced current doesn't need any energy
- 2) energy conservation is violated in this case
- 3) there is less KE in case 2
- 4) there is more gravitational PE in case 2

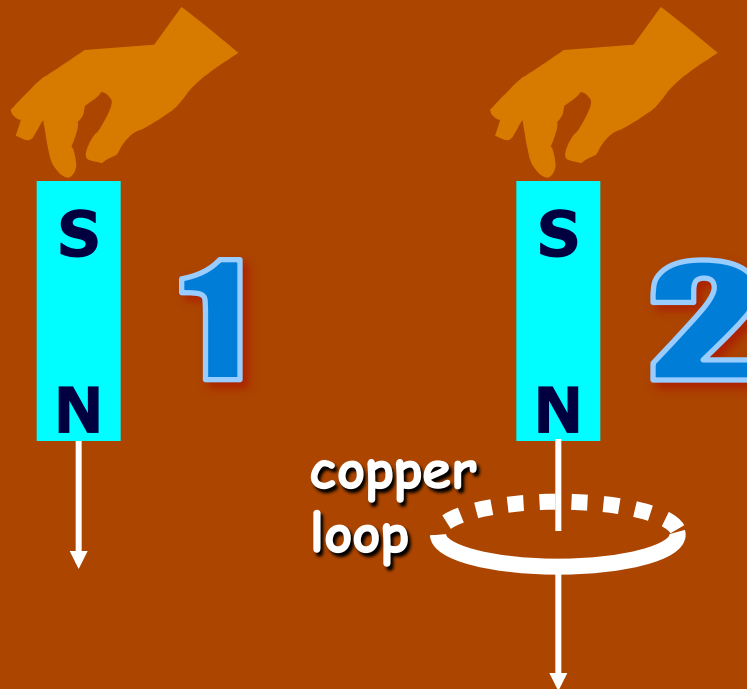

# ConceptTest 21.7b Falling Magnet II

If there is induced current, doesn't that cost energy? Where would that energy come from in case 2?

- 1) induced current doesn't need any energy
- 2) energy conservation is violated in this case
- 3) there is less KE in case 2
- 4) there is more gravitational PE in case 2

In both cases, the magnet starts with the same initial gravitational PE. In case 1, all the gravitational PE has been converted into kinetic energy. In case 2, we know the magnet falls slower, thus there is **less KE**. The **difference in energy** goes into making the induced current.

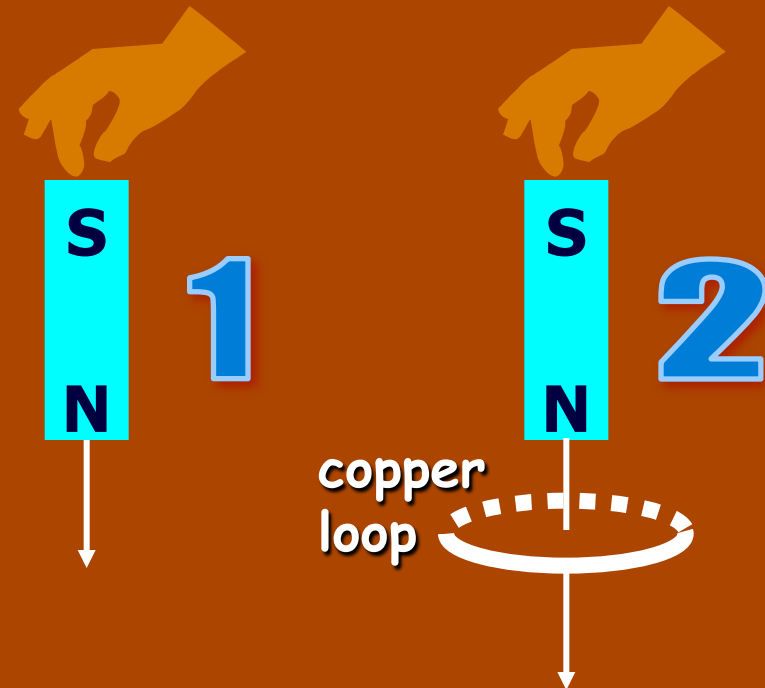

## ConceptTest 21.8a Loop and Wire I

A wire loop is being pulled away from a current-carrying wire.

What is the direction of the induced current in the loop?

- 1) clockwise
- 2) counterclockwise
- 3) no induced current

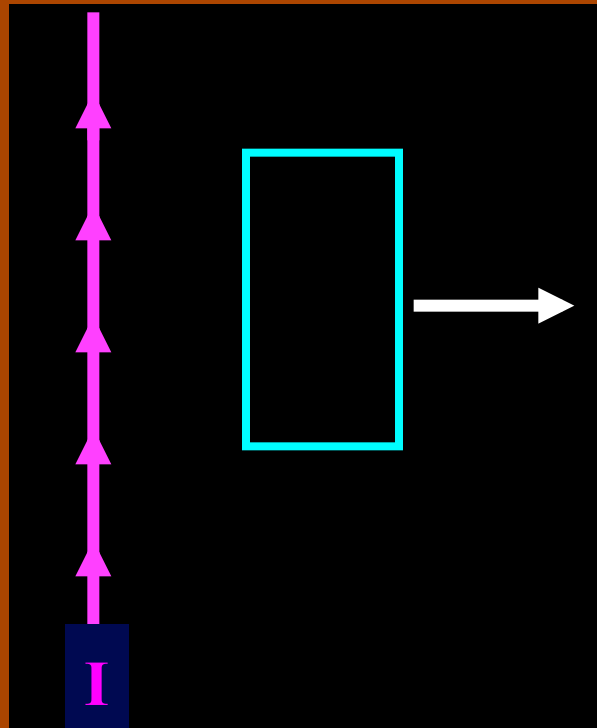

## ConceptTest 21.8a Loop and Wire I

A wire loop is being pulled away from a current-carrying wire.

What is the direction of the induced current in the loop?

- 1) clockwise
- 2) counterclockwise
- 3) no induced current

The magnetic flux is *into the page* on the right side of the wire and *decreasing* due to the fact that the loop is being pulled away. By Lenz's Law, the induced  $B$  field will *oppose this decrease*. Thus, the new  $B$  field points *into the page*, which requires an induced *clockwise* current to produce such a  $B$  field.

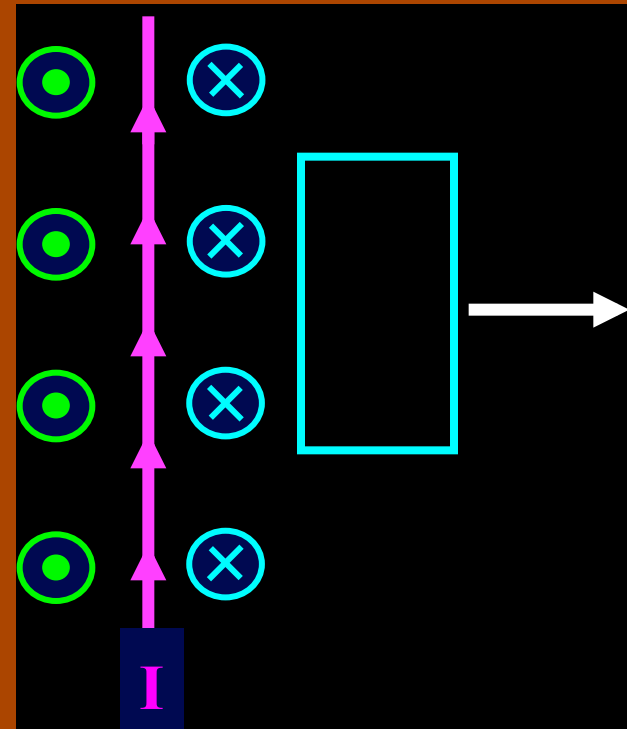

## ConceptTest 21.8b Loop and Wire II

What is the induced current if the wire loop moves in the direction of the **yellow arrow** ?

- 1) **clockwise**
- 2) **counterclockwise**
- 3) **no induced current**

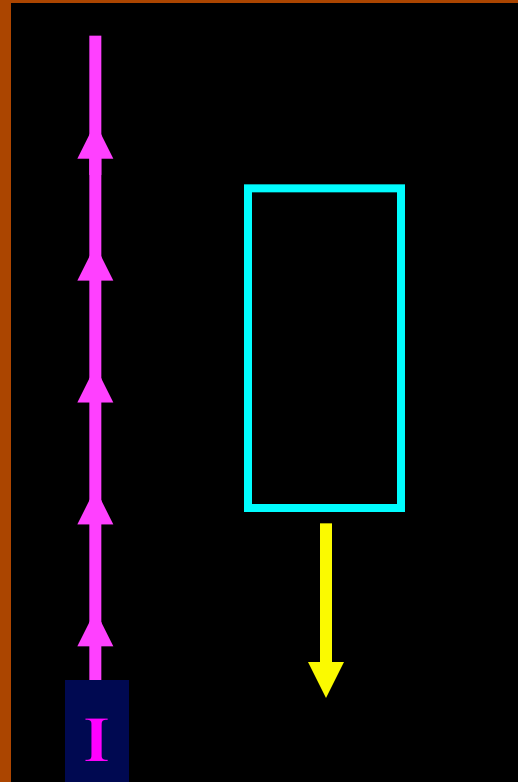

## ConceptTest 21.8b Loop and Wire II

What is the induced current if the wire loop moves in the direction of the **yellow arrow** ?

- 1) clockwise
- 2) counterclockwise
- 3) no induced current

The magnetic flux through the loop is **not changing** as it moves parallel to the wire. Therefore, there is **no induced current**.

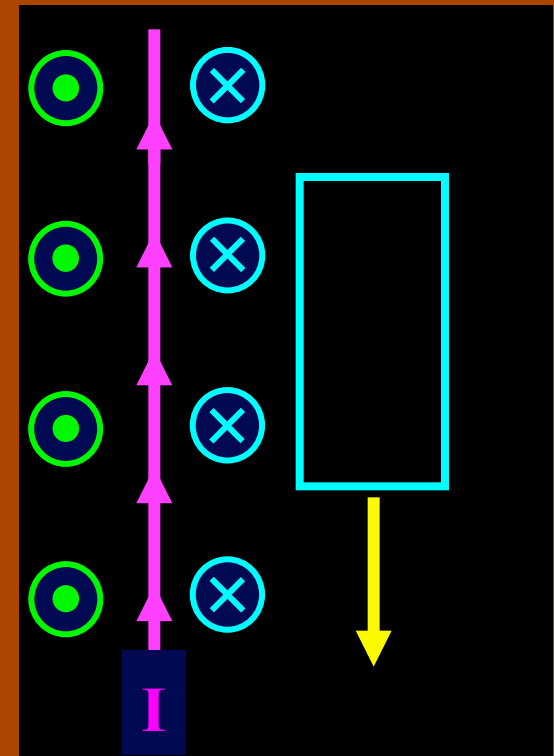

## ConceptTest 21.9 Motional EMF

A conducting rod slides on a conducting track in a constant  $B$  field directed into the page.

What is the direction of the induced current?

- 1) clockwise
- 2) counterclockwise
- 3) no induced current

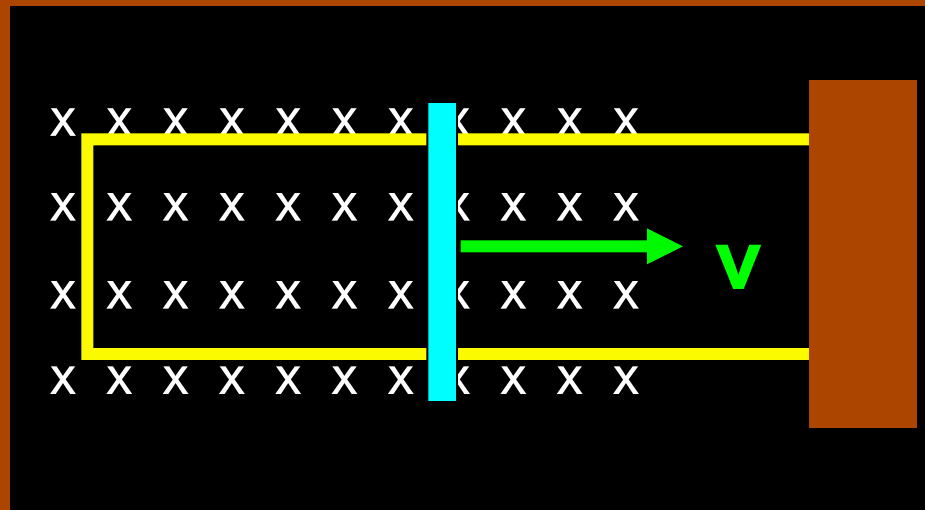



## ConceptTest 21.9 Motional EMF

A conducting rod slides on a conducting track in a constant  $B$  field directed into the page.

What is the direction of the induced current?

- 1) clockwise
- 2) counterclockwise
- 3) no induced current

The  $B$  field points *into the page*. The flux is *increasing* since the area is increasing. The induced  $B$  field opposes this change and therefore points *out of the page*. Thus, the induced current runs *counterclockwise* according to the right-hand rule.

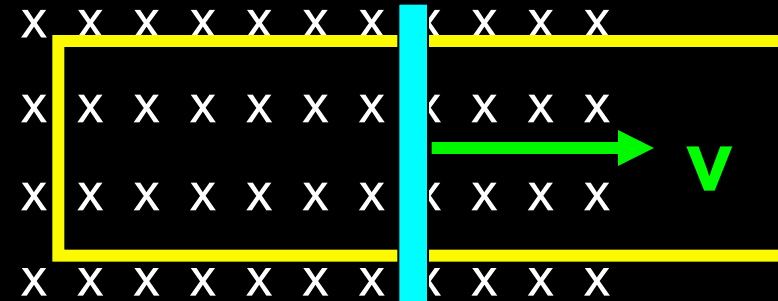

**Follow-up:** What direction is the magnetic force on the rod as it moves?

## ConceptTest 21.10 Generators

A generator has a coil of wire rotating in a magnetic field.

If the *rotation rate increases*, how is the *maximum output voltage* of the generator affected?

- 1) increases
- 2) decreases
- 3) stays the same
- 4) varies sinusoidally

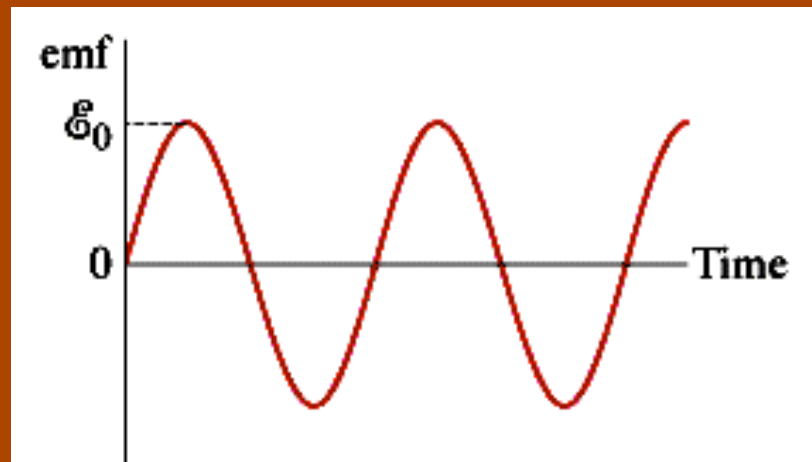

## ConceptTest 21.10 Generators

A generator has a coil of wire rotating in a magnetic field. If the **rotation rate increases**, how is the **maximum output voltage** of the generator affected?

- 1) increases
- 2) decreases
- 3) stays the same
- 4) varies sinusoidally

The maximum voltage is the leading term that multiplies  $\sin(\omega t)$  and is given by  $\epsilon_0 = NBA\omega$ . Therefore, if  $\omega$  increases, then  $\epsilon_0$  must increase as well.

$$|\mathcal{E}| = NBA\omega \sin(\omega t)$$

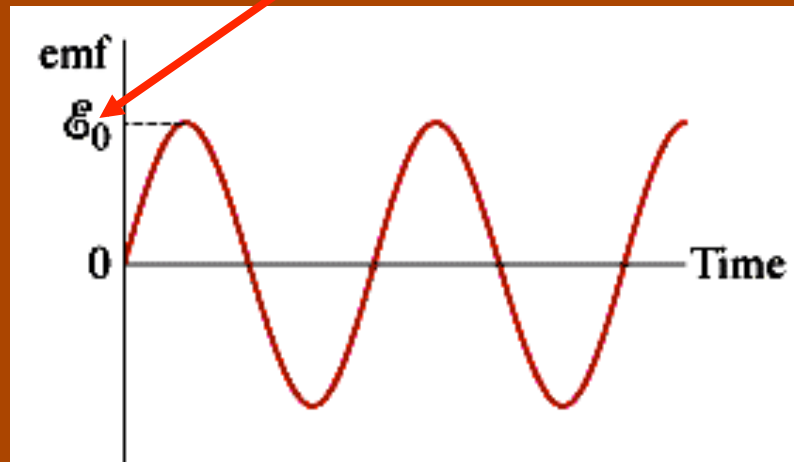

## ConceptTest 21.11 Magic Loop

A wire loop is in a uniform magnetic field. Current flows in the wire loop, as shown. What does the loop do?

- (1) moves to the right
- (2) moves up
- (3) remains motionless
- (4) rotates
- (5) moves out of the page

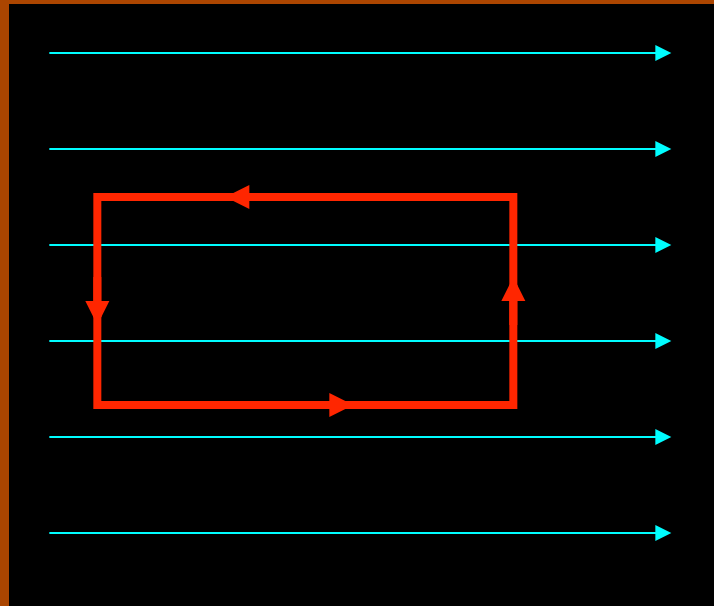

## ConceptTest 21.11 Magic Loop

A wire loop is in a uniform magnetic field. Current flows in the wire loop, as shown. What does the loop do?

- (1) moves to the right
- (2) moves up
- (3) remains motionless
- (4) rotates
- (5) moves out of the page

There is no magnetic force on the top and bottom legs, since they are parallel to the  $B$  field. However, the magnetic force on the **right side** is **into the page**, and the magnetic force on the **left side** is **out of the page**. Therefore, the entire loop will tend to rotate.

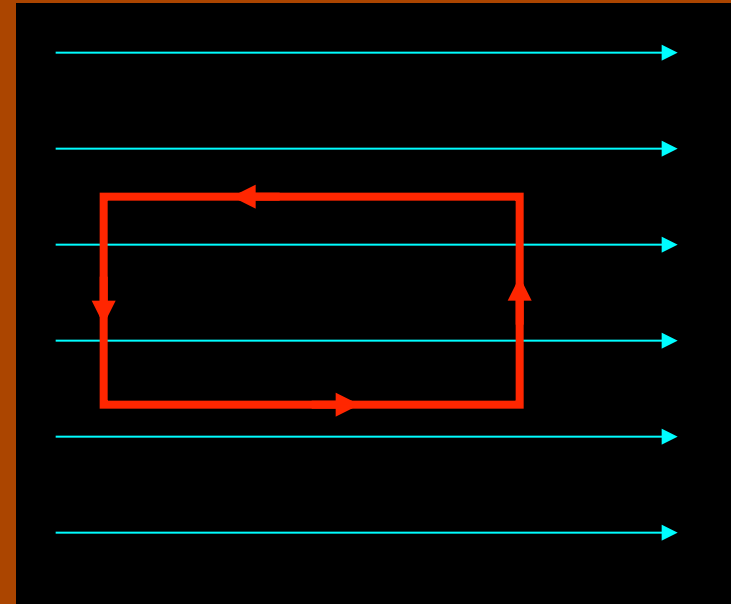

**This is how a motor works !!**

# ConceptTest 21.12a Transformers I

What is the voltage  
across the lightbulb?

- 1) 30 V
- 2) 60 V
- 3) 120 V
- 4) 240 V
- 5) 480 V

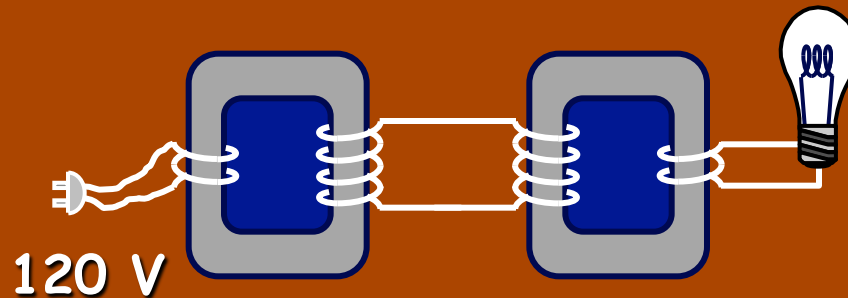

# ConceptTest 21.12a Transformers I

What is the voltage across the lightbulb?

1) 30 V

2) 60 V

3) 120 V

4) 240 V

5) 480 V

The first transformer has a 2:1 ratio of turns, so the voltage doubles. But the second transformer has a 1:2 ratio, so the voltage is halved again. Therefore, the end result is the same as the original voltage.

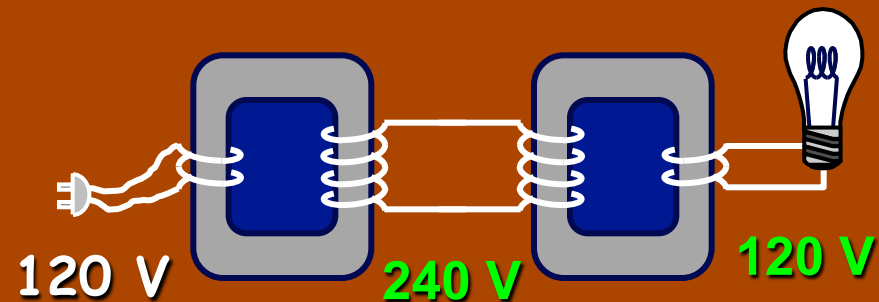

# ConceptTest 21.12b Transformers II

Given that the intermediate current is 1 A, what is the current through the lightbulb?

- 1)  $1/4$  A
- 2)  $1/2$  A
- 3) 1 A
- 4) 2 A
- 5) 5 A

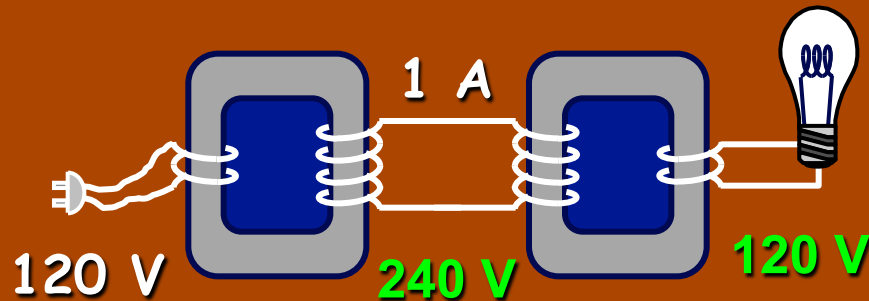



# ConceptTest 21.12b Transformers II

Given that the intermediate current is 1 A, what is the current through the lightbulb?

1) 1/4 A

2) 1/2 A

3) 1 A

4) 2 A

5) 5 A

Power in = Power out

$$240 \text{ V} \times 1 \text{ A} = 120 \text{ V} \times ???$$

The unknown current is 2 A.

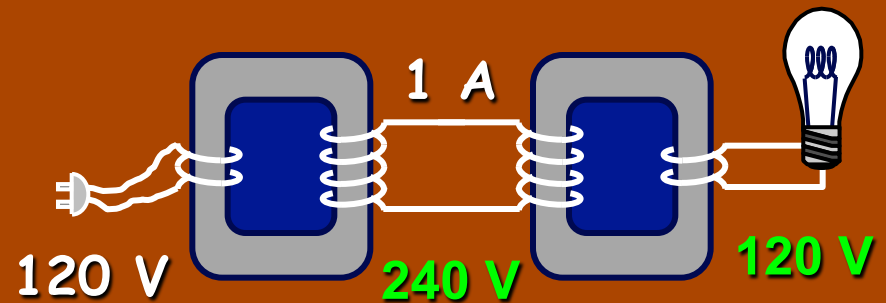

# ConcepTest 21.12c Transformers III

A 6 V battery is connected to one side of a transformer. Compared to the voltage drop across coil A, the voltage across coil B is:

- 1) greater than 6 V
- 2) 6 V
- 3) less than 6 V
- 4) zero

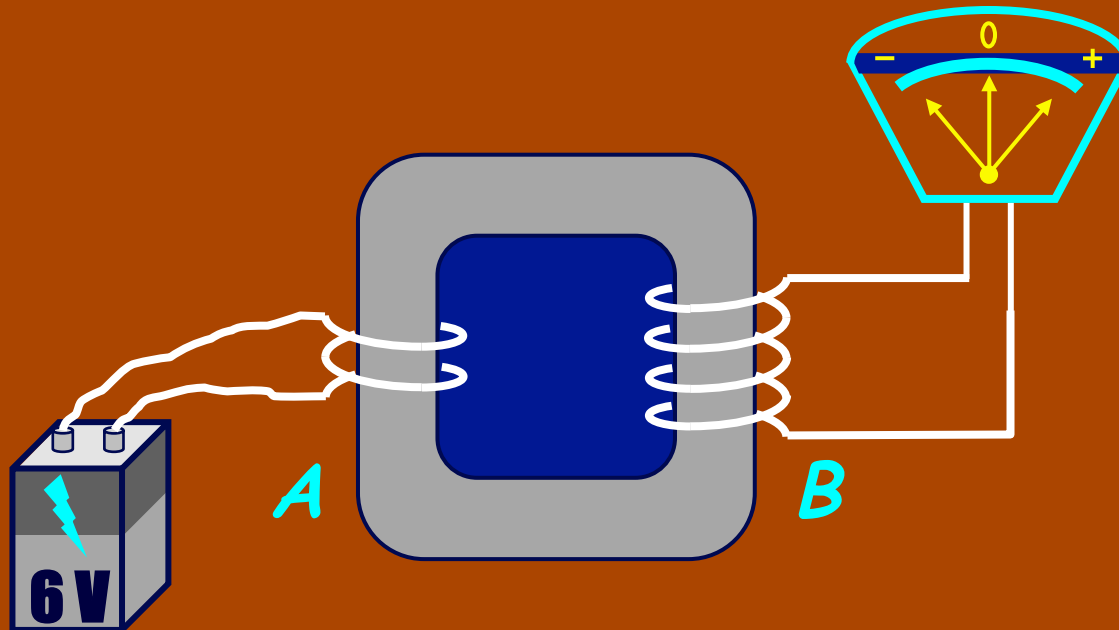

# ConcepTest 21.12c Transformers III

A 6 V battery is connected to one side of a transformer. Compared to the voltage drop across coil A, the voltage across coil B is:

- 1) greater than 6 V
- 2) 6 V
- 3) less than 6 V
- 4) zero

**The voltage across B is zero.**  
Only a **changing** magnetic flux induces an EMF. Batteries can only provide **DC current**.

